



CAPABILITIES OVERVIEW



OUR BRANDS

IR *Ingersoll Rand*

AIRMAN

KOHLER

Kawasaki

EST
GmbH
Filtrations-Separations-Technik

hertz[®]
KOMPRESSOREN

neuros

**IN
MA
TEC**
GAS-TECHNOLOGIE



Sauer Compressors

SPXFLOW



OUR EXPERIENCE YOUR ADVANTAGE.

CAPS is a privately owned Australian company that began operations in 1980. CAPS has built its business and reputation on its ability to custom design, manufacture, supply and service a wide range of compressed air and power generation technology.

CAPS supplies its diverse industrial products to mining, packaging, manufacturing, food and beverage, waste water treatment and oil and gas clients throughout Australia and internationally.

The 180+ strong team across 9 Australian branches are committed to delivering world-class, innovative and smarter solutions to their valued customers. Unlike its Australian competitors, CAPS offers full customisation on the majority of their products to meet customer's specific needs and requirements.

CORE PRODUCTS & SERVICES

AIR COMPRESSORS	Reciprocating, Rotary, Centrifugal, Electric & Diesel Driven
BLOWERS	Positive Displacement, Single & Multi Stage Centrifugal, Turbo Blowers
POWER GENERATORS	Diesel & Gas Driven Power Generators from 5-3300kva
GAS GENERATORS	Supply of Nitrogen and Oxygen Generators
COMPRESSED AIR SYSTEM ASSOCIATED EQUIPMENT	Air Dryers, Filters, Master Controllers
PRESSURE & PROCESS VESSELS	Manufactured to AS1210, ASME VIII & Other Special Purpose Built Vessels
AIR TOOLS, AIR WINCHES, AIR-DRIVEN EQUIPMENT	Air Motors, Hoists Diaphragm Pumps, etc.
PRE-SALE / AFTER-SALE TECHNICAL EXPERTISE & SUPPORT	Air Audits, Installations, Equipment Servicing, Field Testing, Maintenance Contracts, Equipment Upgrades, Overhauls/Rebuilds, Parts.
BRANDS (MOST POPULAR)	Ingersoll Rand, Airman, Kohler, CAPS, Hertz, Inmatec, Neuros, Pedro Gil, Kawasaki Heavy Industries & FST



WHAT MATTERS TO YOU, MATTERS TO US.

A PROFESSIONAL, EXPERIENCED PARTNER

For 40 years, CAPS has been helping thousands of businesses source flexible solutions that reduce costs, increase uptime and deliver value.

We believe in partnerships. We are not looking for "clients" or "customers" but for partners. We believe in long-term relationships that bring value to both businesses. We believe in win-wins. You are experts in your field and we are experts in ours, so we listen to understand your needs then use our expertise to address them.

When you partner with CAPS, you can rest assured that you will have a dedicated overriding Business Support Manager, who is backed up by a reliable network of local and national contacts. With formal escalation strategies in place, you will always have access to the right people who can provide expert support when required.

RISK MITIGATION

We take the initiative to keep our customers informed of current and future circumstances that may impact safety, compliance, productivity and the performance of their equipment.

SAFETY & COMPLIANCE

We understand that OH&S is an area of critical importance for most businesses. At CAPS, we put safety at the core of everything we do. We work across many customer sites and many industries, which means we need a solid safety management system that works. Where required we can also adopt our customer's safety systems. Just some of the activities we undertake to manage OH&S are:

- Site Hazard Identification and Risk Assessment with control policies and procedures
- Development of Site Safety Plans and associated Safe Work Method Statements
- Development of Safety Absolutes and a National Safety Committee to uphold positive safety behaviours
- Improving our safety culture by positive engagement and communication
- Sharing best practice across our branch network and with industry peers

CAPS SAFETY STATISTICS

Total Recordable Injury Frequency Rate - TRIFR (as of 30/09/19): 0

Lost Time Injury Frequency Rate - LTIFR (as of 30/09/19): 0

FLEXIBLE OPTIONS THAT MEET YOUR NEEDS

Unlike an OEM, CAPS has access to a broad range of options and alternative equipment technologies that ensures we can best match our offering to your needs.

As the national distributor for Ingersoll Rand, Airman, KOHLER and more CAPS has access to world-renowned suppliers and can supplement our offering with other select brands and equipment types to best support your exacting requirements.

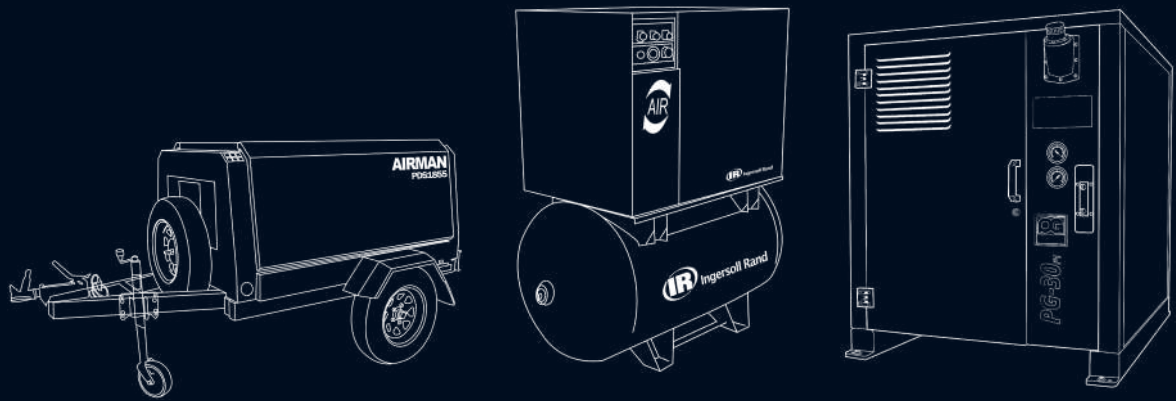

"CAPS were on time and maintenance work was carried out smoothly. Any repairs required were communicated and repaired without any issues. Technicians carrying out the maintenance were competent and approachable."

-Graeme Hollands, BGIS

"Very knowledgeable about your products and found the best product to suit our needs"

-Kathy Sepic, Sevtech

"After repeat visits to the work site, the site is always tidy, consumables well stacked, caution tape and tag always up and visible, correct tools on hand, good manual handling on display, plus a few other good practices. As you are aware these actions are the cornerstone of safety [and reliability] and something that Woodside is pretty keen on. As an ex-fitter, a clean well drilled work site means the job is under control and things are in hand. Keep up the shining example."

-Jon Harvey, Woodside Energy

YOUR 24/7 NATIONWIDE SERVICE PARTNER.

Partnering with CAPS means you are partnering with a team of technical specialists with a broad technical skill base across multiple machine brands and types.

// ROBUST & RELIABLE

ROBUST AND RELIABLE. Your equipment needs to consistently start the first time, cope with rough handling and deliver strong performance.



// DYNAMIC FLEXIBILITY

DYNAMIC FLEXIBILITY. To drive maximum profitability on your site, your service partner needs to move swiftly with changes in your business.



9 BRANCHES

// RAPID RESPONSE

RAPID RESPONSE. Easy and immediate access to technical support is essential. Branches across Australia with fully equipped workshops, on-call technicians and local administration teams.



**WHEREVER
YOU ARE
WE'RE NEVER
TOO FAR**



// ALWAYS ON

ALWAYS ON. You'll have complete confidence in your equipment to ensure that they're always working uninterrupted.



// 100% DEPENDABILITY

100% DEPENDABILITY. You need an approachable, highly knowledgeable provider to work closely with you to best maximise all of your technologies on site.



// SUSTAINABLE CHOICES

SUSTAINABLE CHOICES. Being able to identify opportunities to contribute to your bottom line and enhance your energy efficiency is essential.



// CONSISTENT OUTCOMES

CONSISTENT OUTCOMES. Preventative maintenance programs deliver extended machine life and running efficiency, driving down overall costs.



**60+ HIGHLY
EXPERIENCED
& TRAINED
TECHNICIANS**





LOCAL CENTRIFUGAL REBUILD & SERVICE CAPABILITIES

CAPS have 9 local service centres where our highly-trained technicians can provide new and refurbished airends, genuine and performance parts, routine servicing, and more for all equipment makes and models, including competitor machines. We can also provide controls assistance with a resident dedicated controls engineer with accredited project management certification.

ONE OF OUR REBUILD CENTRES



AUSTRALIA'S LARGEST CENTRIFUGAL SERVICE TEAM

CAPS Australia's National CENTAC Team is the largest centrifugal service team in Australia – three times larger than our nearest competitor. Using highly advanced, state-of-the-art software from Ingersoll Rand, our technicians are able to assess several parameters of each centrifugal compressor to ensure that they deliver a long service life. CAPS is the only company in Australia that can simulate CENTAC performance runs and compare it with site taken data taken by certified CENTAC technicians. These three indicators provide good feedback on the overall health of each centrifugal compressor unit.



BELLIS & MORCOM COMPRESSOR REBUILD

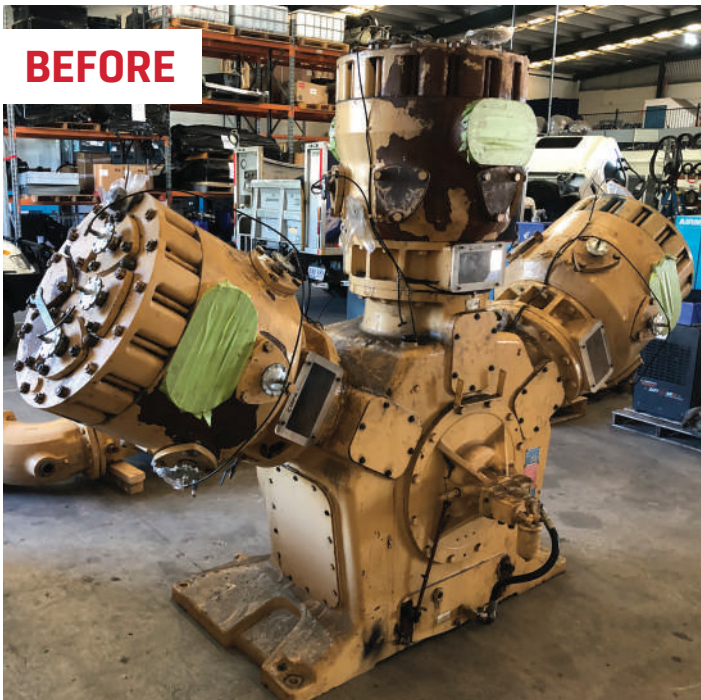

INGERSOLL RAND CENTAC COMPRESSOR REBUILDS



WHAT CAN YOU EXPECT FROM A CAPS REBUILD?

- A complete disassembly and inspection of the airend
- All bearings, journals, gear fits, and bearing bores are visually inspected and measured
- All housings and rotor sets are inspected for damage
- Usually the installation of bearings, seals, gaskets, and o-rings with new premium quality parts
- All metal repairs are performed
- Rotor sets are dynamically balanced
- The airend is then assembled, pressure-tested, painted and palletised

RECENT LANDMARK PROJECTS.

COMPRESSOR PROJECTS

PROJECT NAME	SCOPE OF SUPPLY	VALUE
KONIAMBO NICKEL PROJECT, NEW CALEDONIA	3 x centrifugal oil-free compressors, vessels & dryers	\$4.3M
TOMAGO ALUMINIUM, NEWCASTLE, NSW	3 x Centrifugal Oil Free Compressors	\$1.5M
ASTRA ZENECA, SYDNEY, NSW	2 x Centrifugal Oil Free Compressors	\$0.8M
RIO TINTO, YANDI, WA	Compressor skid packages and air receivers	\$0.8M
QCLNG, BRISBANE, QLD	3 x Containerised Instrument Air Systems	\$0.7M
FONTERA AUSTRALIA, MELBOURNE, VIC	2 x 160kw VSD Oil Free Air Systems	\$0.5M

POWER GENERATION PROJECTS

PROJECT NAME	SCOPE OF SUPPLY	VALUE
LEND LEASE, BARANGAROO, SYDNEY, NSW	15 diesel generator sets	\$14M
MUNDARING WEIR WATER TREATMENT PLANT, PERTH, WA	1 x 3300kva & 2 x 2800kva Generators	\$4M
CAIRNS BASE HOSPITAL, CAIRNS, QLD	2200kva generator & installation	\$2.6M
GOREHILL DATA CENTRE, SYDNEY, NSW	3 x 2500kva generators & installation	\$2.5M
NORTH BEACHES HOSPITAL, SYDNEY, NSW	Co-gen Generator and Fuel Tank Installation	\$1.6M
INPEX ICTHYCS ACCOMMODATION VILLAGE, DARWIN, NT	2 x 275kva custom generators	\$1.3M

BLOWER PROJECTS

PROJECT NAME	SCOPE OF SUPPLY	VALUE
ANGLO GOLD	Kawasaki blower	\$1.4M
GIPPSLAND WATER	3 X Next Turbo Blowers	\$1M
METSO - FINEX OFF GAS	Centrifugal blower	\$1M
TOWNSVILLE WASTE WATER, QLD	10 x positive displacement blowers	\$0.5M
FL SMIDTH	3 x 200kw centrifugal blowers	\$0.3M
CRISTAL PIGMENT AUSTRALIA	3 x 90kw positive displacement blowers	\$0.2M
PILGANGOORA LITHIUM-TANTALUM PROJECT, WA	2 x positive displacement blowers	\$0.15M

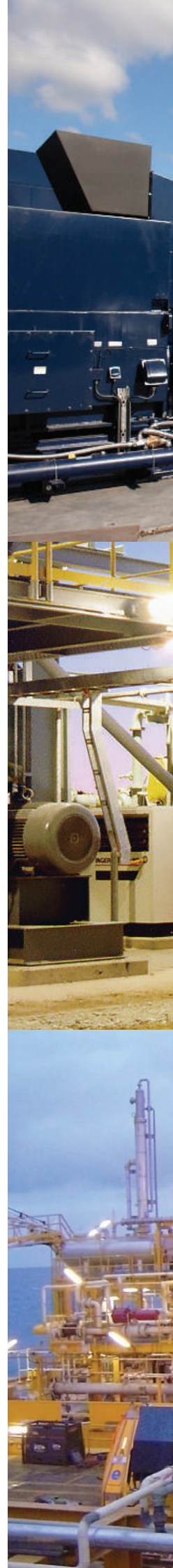

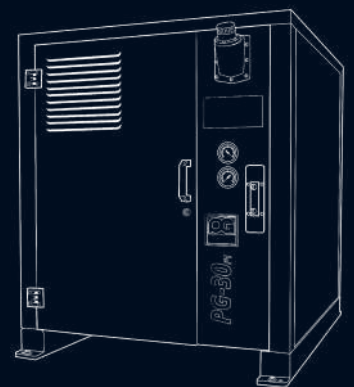
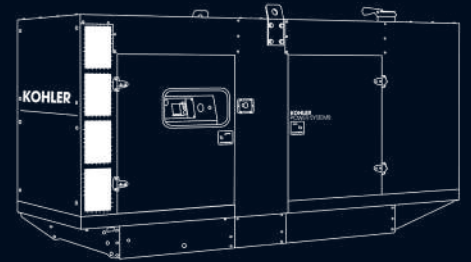
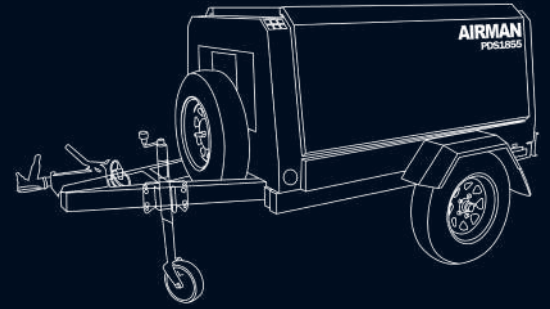

**40 YEARS
GLOBAL
CROSS-SECTOR
EXPERIENCE**

CUSTOM-ENGINEERED SOLUTIONS



ENGINEERING AND MANUFACTURING CAPABILITIES

2,200 sqm, ISO9001 accredited manufacturing facility in Welshpool, Western Australia. Management of total design, development and manufacturing of specialised one-off compressor, generator and blower packages.



PROJECT MANAGEMENT

- Can provide full material traceability.
- CAPS is a leader in its field and has a strong reputation for producing world class industrial packages.
- Experienced in understanding and providing the documentation requirements of today's demanding customers.



SKID PACKAGES

- Hundreds of engineered skid packages have been designed and built by CAPS for customers in Australian and 38 countries worldwide.
- Fully assembled and tested.
- Single point power and signal connections.
- Skid base and roof structure is designed to Australian standard cyclone ratings.



TEST BOOTH

CAPS' manufacturing division offers businesses the unique capability to calibrate, test, monitor and record critical data for a wide range of plant and equipment.

Fast-tracks site installation so users can simply plug and play.



SERVICE SOLUTIONS

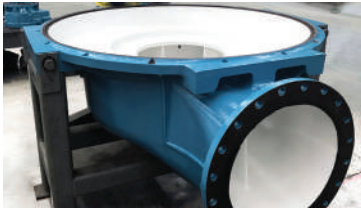

REPAIRS

Our industry leading breakdown support operates 24 hours a day, 365 days a year. Our technician's combined depth of experience means that we can rapidly find solutions to customers concerns, minimising the effect of delays and downtimes.



REBUILDS

For industrial machinery that appears to be near the end of its useful life, an overhaul can give your air compressor or blower a new lease of life, saving you many thousands of dollars on replacement costs.



FIXED PRICE SERVICE PLANS

The best way to avoid breakdowns is to have your equipment serviced regularly. CAPS flexible service and support programs are designed to minimise equipment faults and unscheduled downtime which can cost you thousands straight off your bottom line.

ADDITIONAL SERVICES



ENERGY EFFICIENCY AUDITS

Outdated technologies, poorly sized equipment, inadequate control systems and air leaks can lead to efficiency losses and poor reliability that can cost your company thousands.

CAPS deliver a complete range of auditing solutions that are at the forefront of the compressed air industry. We have a system approach mentality that provides long term sustainable and financially rewarding solutions to your compressed air needs.



CAPS RENTAL AIR AND AIR TREATMENT

CAPS range of hire equipment includes electric rotary screw compressor packages with air receivers, desiccant and refrigerative dryers, 1000 volt and 415 volt 'minpack' compressors, positive displacement blowers, diesel powered rotary screw compressors, gas generation products, oil free electric compressors, reciprocating compressors, air tools and accessories.

CAPS ROTARY SCREW AIR COMPRESSORS



DESCRIPTION	Tank Mounted with Integrated Air Dryer
RANGE	5.5kW (7.5hp) to 15kW (20hp)
CAPACITY	0.77m ³ /min (27cfm) - 2.25m ³ /min (79cfm)
PRESSURE	7.5 bar (110psi) - 13 bar (190psi)



DESCRIPTION	Base Mounted - Belt Drive
RANGE	18kW (25hp) to 160kW (200hp)
CAPACITY	3.3m ³ /min (117cfm) - 27.4m ³ /min (968cfm)
PRESSURE	7.5 bar (110psi), 10 bar (145 psi), 13 bar (190psi)



DESCRIPTION	Base Mounted - Direct Drive
RANGE	22kW (30hp) to 315kW (430hp)
CAPACITY	4m ³ /min (141cfm) - 27.4m ³ /min (1,872cfm)
PRESSURE	7.5 bar (110psi), 10 bar (145psi)



DESCRIPTION	High Efficiency - Variable Speed Drive
RANGE	18kW (25hp) to 315kW (430hp)
CAPACITY	3.5m ³ /min (124cfm) - 54.1m ³ /min (1,910cfm)
PRESSURE	7.5 bar (110psi), 10 bar (145psi), 13 bar (190psi)



DESCRIPTION	Modified for Outdoor Conditions
RANGE	50kW (68hp) to 315kW (430hp)
CAPACITY	0.9m ³ /min (32cfm) - 53m ³ /min (1,872cfm)
PRESSURE	7.5 bar (108psi) - 13 bar (188psi)



DESCRIPTION	Oil Free - Scroll Compressor - 100% Oil Free - Class 0
RANGE	2.2kW (3hp) to 37kW (50hp)
CAPACITY	0.22m ³ /min (9.6cfm) to 4.16m ³ /min (147cfm)
PRESSURE	8 bar (116psi) 9.9 bar (143psi)



DESCRIPTION	Oil Free - Rotary Screw - Gear Drive - 100% Oil Free - Class 0
RANGE	90kW (125hp) to 355kW (480hp)
CAPACITY	0.9m ³ /min (32cfm) - 53m ³ /min (1,872cfm)
PRESSURE	7 bar (100psi), 8.5 bar (125psi) 10 bar (145psi)

INGERSOLL RAND ROTARY SCREW AIR COMPRESSORS



DESCRIPTION	Tank Mounted with Integrated Air Dryer
RANGE	5.5kW (7.5hp) to 15kW (20hp)
CAPACITY	0.77m ³ /min (27cfm) - 2.25m ³ /min (79cfm)
PRESSURE	7.5 bar (110psi) - 13 bar (190psi)



DESCRIPTION	Fixed Speed - Gear Drive
RANGE	30kW (50hp) to 250kW (340hp)
CAPACITY	5.6m ³ /min (198cfm) to 54m ³ /min (1911cfm)
PRESSURE	7.5 bar (110psi), 8.5 bar (125psi), 10 bar (145 psi), 14 bar (203psi)



DESCRIPTION	Modified for Outdoor Conditions / Miners Pack
RANGE	55kW (75hp) to 250kW (340hp)
CAPACITY	10.19m ³ /min (360cfm) to 54m ³ /min (1,911cfm)
PRESSURE	7.5 bar (110psi), 8.5 bar (125psi), 10 bar (145psi), 14 bar (203psi)



DESCRIPTION	High Efficiency - Variable Speed Drive
RANGE	55kW (75hp) to 250kW (300hp)
CAPACITY	10.53m ³ /min (372cfm) to 53m ³ /min (1,875cfm)
PRESSURE	7 bar (100psi), 8.5 bar (125psi), 10 bar (145psi)



DESCRIPTION	Premium Efficiency - Hybrid Permanent Magnet Motor
RANGE	55kW (75hp) to 160kW (200hp)
CAPACITY	10.53m ³ /min (372cfm) to 32m ³ /min (1,132cfm)
PRESSURE	7 bar (100psi), 7.5 bar (110psi), 8 bar (116psi), 8.5 bar (125 psi), 10 bar (145psi)



DESCRIPTION	Offshore Compressor - Division 1, Zone 1
RANGE	55kW (75hp) to 160kW (200hp)
CAPACITY	10.19m ³ /min (360cfm) to 29.2m ³ /min (1,031cfm)
PRESSURE	7 bar (100psi), 8.5 bar (125psi), 10 bar (145psi)

ROTARY SCREW AIR COMPRESSORS - OIL FREE



DESCRIPTION	Oil Free - Gear Drive - 100% Oil Free - Class 0
RANGE	37KW (50hp) to 300KW (40hp)
CAPACITY	0.77 m ³ /min (27cfm) to 2.25m ³ /min (79cfm)
PRESSURE	7.5 bar (110psi) - 13 bar (190psi)



DESCRIPTION	Oil Free - Premium Efficiency - HPM Motor - 100% Oil Free Class 0
RANGE	37KW (50hp) to 160kW (200hp)
CAPACITY	3.3m ³ /min (117cfm) to 27.4m ³ /min (968cfm)
PRESSURE	7 bar (100psi), 7.5 bar (110psi), 8 bar (116psi), 8.5 bar (125psi), 10 bar (145 psi)

CENTRIFUGAL AIR COMPRESSORS - OIL FREE



DESCRIPTION	Centac - Oil Free - TUV Certified - Class 0
RANGE	275kW (375hp) - 4,500kW (6,000hp)
CAPACITY	45m ³ /min (1,590cfm) – 800m ³ /min (28,200cfm)
PRESSURE	3 bar (45psi) to 10 bar (145psi)



DESCRIPTION	High Pressure
RANGE	600kW (800hp) to 3,400kW (4,500hp)
CAPACITY	50m ³ /min (1,765cfm) to 425m ³ /min (15,000cfm)
PRESSURE	11 bar (160psi) to 42 bar (610psi)



DESCRIPTION	IHI Dalgakiran - Turbo Compressor
RANGE	125kW (170hp) to 1850kW (2,480hp)
CAPACITY	23m ³ /m (812cfm) to 350m ³ /m (12,360cfm)
PRESSURE	2 bar (30psi) to 16 bar (232psi)

HIGH PRESSURE COMPRESSORS



DESCRIPTION	Ingersoll Rand Type 30 - Oil Injected
RANGE	2.2kW (3hp) to 15kW (20hp)
CAPACITY	0.14m ³ /min (4.8cfm) to 1.07m ³ /min (37.3cfm)
PRESSURE	35 bar (507psi) to 345 bar (5,000psi)



DESCRIPTION	Hertz PET MASTER - Oil Free
RANGE	260kW (350hp) to 560kW (750hp)
CAPACITY	25.37m ³ /min (896cfm) to 56.12m ³ /min (1982cfm)
PRESSURE	40 bar (580psi)

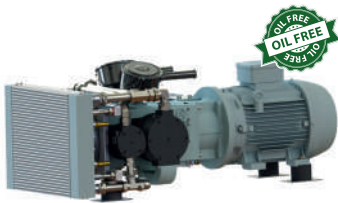

DESCRIPTION	Sauer Harmattan - Oil Free - Air / Nitrogen / Gas
RANGE	2.2kW (3hp) to 110kW (150hp)
CAPACITY	0.2m ³ /min (7cfm) to 33m ³ /min (1177cfm)
PRESSURE	5 bar (72psi) to 100 bar (1,450psi)



DESCRIPTION	Sauer - Air / Nitrogen
RANGE	3kW (4hp) to 90kW (120hp)
CAPACITY	0.13m ³ /min (4.6cfm) to 7.33m ³ /min (258cfm)
PRESSURE	8 bar (115psi) to 100 bar (1,450psi)



DESCRIPTION	Sauer - Air / Nitrogen / Helium / Natural Gas / Bio-methane
RANGE	10kW (13hp) to 230kW (308hp)
CAPACITY	0.5m ³ /min (17.6cfm) to 16.6m ³ /min (586cfm)
PRESSURE	10 bar (145psi) to 500 bar (7,251psi)



DESCRIPTION	PET Star Reciprocating - Oil Free
RANGE	112kW (150hp) to 525kW (725hp)
CAPACITY	44m ³ /min (1891 cfm) to 65m ³ /min (2,300cfm)
PRESSURE	30 bar (435psi) to 42 bar (690psi)

ON-SITE GAS GENERATORS



DESCRIPTION	INMATEC Pressure Swing Adsorption (PSA)
CAPACITY	0.5 to 10,000 Nm ³ /hr
PURITY	95% to 99.9999%



DESCRIPTION	INMATEC Membrane Technology
CAPACITY	0.14 to 2,500 Nm ³ /hr
PURITY	95% to 99.0%



DESCRIPTION	INMATEC Oxygen Generator
CAPACITY	0.5 to 2,000 Nm ³ /hr
PURITY	90% to 95%



OPTIONS	<ul style="list-style-type: none"> • Container Solutions • ONSHORE Solutions and OFFSHORE Solutions • Redundant Designs • Explosion Protection • ATEX Designs
----------------	--



DESCRIPTION	Won Hi Tech Nitrogen Generator
CAPACITY	0.5 to 3,000 Nm ³ /hr
PURITY	95% to 99.9999%



DESCRIPTION	Won Hi Tech Membrane Nitrogen Generator
CAPACITY	0.17 to 1,000 Nm ³ /hr
PURITY	95% to 99.9%



DESCRIPTION	Won Hi Tech Oxygen Generator
CAPACITY	3.0 to 130 Nm ³ /hr
PURITY	90% to 95%

AIR TREATMENT EQUIPMENT

AIR DRYERS



DESCRIPTION	CAPS Refrigerated Air Dryers
CAPACITY	0.5m ³ /min (19cfm) to 90m ³ /min (3,182cfm)
PRESSURE	5 bar (72.5psi) to 14 bar (203psi)
DEWPOINT	3°C to 5°C



DESCRIPTION	CAPS High Efficiency- Phase Change Material (CDRP)
CAPACITY	3.39m ³ /min (120cfm) to 18m ³ /min (636cfm)
PRESSURE	5 bar (72.5psi) to 14 bar (203psi)
DEWPOINT	3°C to 5°C



DESCRIPTION	Heatless Desiccant Air Dryer – Standard / with Carbon Tower / Breathing Air (DPS / DPS-A / DPS-BI / DPS-BM)
CAPACITY	0.13m ³ /min (4.6cfm) to 105m ³ /min (3708cfm); Plus Custom
PRESSURE	6 bar (87psi) to 14 bar (203psi)
DEWPOINT	-25°C to -70°C



DESCRIPTION	Heatless Desiccant Air Dryer – High Pressure (DHW)
CAPACITY	1.2m ³ /min (4.6cfm) to 26m ³ /min (918cfm); Plus Custom
PRESSURE	25 bar (362psi) to 350 bar (5076psi)
DEWPOINT	-20°C to -55°C



DESCRIPTION	Heat Regenerated Desiccant Air Dryer – Standard /with Steam Heater (DTS)
CAPACITY	6.83m ³ /min (241cfm) to 245m ³ /min (8,652cfm); Plus Custom
PRESSURE	6 bar (87psi) to 11 bar (160psi); Plus Custom
DEWPOINT	-25°C to -70°C



DESCRIPTION	Heat-of-Compression Desiccant Air Dryer
CAPACITY	7m ³ /min (250cfm) to 61m ³ /min (2,165cfm); Plus Custom
PRESSURE	6 bar (87psi) to 10 bar (145psi); Plus Custom
DEWPOINT	-25°C to -70°C



OPTIONS	<ul style="list-style-type: none"> • Container Solutions • ONSHORE Solutions and OFFSHORE Solutions • Explosion Protection • ATEX Designs
----------------	---

INDUSTRIAL BLOWERS



DESCRIPTION	Pedro Gil Tri-lobe Blower
RANGE	5kW (7.5hp) to 315kW (422hp)
FLOW	2m ³ /min (70cfm) to 150m ³ /min (5,330cfm)
PRESSURE	300mbar(g) (4.5psi) to 1,000mbar(g) (15psi)
VACUUM	200mbar(g) to 800mbar(g)



DESCRIPTION	CAPS GHH Rotary Screw Blower
RANGE	55kW (75hp) to 525kW (700hp)
FLOW	25.3m ³ /min (893cfm) to 133m ³ /min (4,055cfm)
PRESSURE	1bar(g) (15psi) to 3.5 bar(g) (50psi)



DESCRIPTION	Multistage Turbo Blowers
RANGE	25kW (30hp) to 1,750KW (2,333hp)
FLOW	8.3m ³ /min (293cfm) to 920m ³ /min (32,490cfm)
PRESSURE	300mbar(g) (4.5psi) to 1.5bar(g) (21psi)



DESCRIPTION	Neuros Turbo Blower
RANGE	22kW (30hp) to 525kW (700hp)
FLOW	23m ³ /min (812cfm) to 532m ³ /min (18,787cfm)
PRESSURE	300mbar(g) (4.5psi) to 2 bar(g) (30psi)



DESCRIPTION	Integrally Geared Single Stage Turbo Blowers
RANGE	75KW (100hp) to 4,500kW (6,034hp)
FLOW	65m ³ /min (2,295cfm) to 2,000m ³ /min (70,625cfm)
PRESSURE	300mbar(g) (4.5psi) to 1.7 bar(g) (25psi)



DESCRIPTION	Kawasaki Single Stage Centrifugal Blowers
RANGE	60kW (80hp) to 3,000kW (4,000hp)
FLOW	60 m ³ /min (2,000cfm) to 1850m ³ /min (60,000cfm)
PRESSURE	300mbar(g) (4.5 psi) to 2 bar(g) (30psi)



DESCRIPTION	Ingersoll Rand Centac - Oil Free - TUV Certified - Class 0
RANGE	130KW(175hp) - 430KW(600hp)
CAPACITY	42m ³ /min (1,483cfm) to 160m ³ /min (5,650cfm)
PRESSURE	1 bar(g) (15psi) - 2 bar(g) (30psi)

CAPS COMPRESSED AIR FILTERS



RANGE	1 / 2" BSP - 3" BSP threaded / 80mm - 200mm flanged
CAPACITY	0.66m ³ /min (23cfm) to 523m ³ /min (18,470cfm)
PRESSURE	Standard model up to 16 bar (232psi). Please refer to CAPS for high pressure models.

CAPS AIR RECEIVERS



DESCRIPTION	Available in a variety of sizes, vertical and horizontal and manufactured to Australian standard AS1210. <ul style="list-style-type: none">• Standard air receivers• Gas scrubber vessels, surge vessels• Vacuum vessels, knock out pots• Air manifolds, large filter housing
--------------------	--

CUSTOM-ENGINEERED PROCESS VESSELS



DESCRIPTION	<p>A high quality manufacturing option for special engineered process vessels. We have the capability to manage the process from end to end. This includes design control and registration, compliance to codes, standards and regulatory requirements, quality assurance of fabrication and protective coating, supply chain management, freight, documentation and final delivery of complete vessel projects.</p> <p>Vessel volumes can range from 10 litres to 50,000 litres and design pressures can range from full vacuum, up to 5000 kPa or even higher. We have an established library of over 500 registered pressure vessels designs, however new code compliant designs can be quickly engineered to your requirements and specifications. CAPS can design your vessel for any given cyclone wind loading or seismic conditions and provide fully documented supporting calculations for critical applications.</p>
--------------------	---

PORTABLE DIESEL AIR COMPRESSORS



DESCRIPTION	Airman Box Portable Compressor
CAPACITY	1.55m ³ /min (55cfm) to 11.3m ³ /min (400cfm)
PRESSURE	7 bar (100psi) to 10 bar (145psi)



DESCRIPTION	Airman Trailer Portable Compressor
CAPACITY	2.8m ³ /min (100cfm) to 11.3m ³ /min (400cfm)
PRESSURE	7 bar (100psi) to 10 bar (145psi)



DESCRIPTION	Airman Large Mobile Compressors
CAPACITY	13.2m ³ /min (466cfm) to 36m ³ /min (1,600cfm)
PRESSURE	7 bar (100psi) to 24 bar (350psi)



DESCRIPTION	Mining Spec Packages
CAPACITY	2.8m ³ /min (100cfm) to 11.3m ³ /min (400cfm)
PRESSURE	7 bar (100psi) to 10 bar (145psi)



AIRMAN & KOHLER POWER GENERATORS



TYPE	Kubota and Isuzu Engines, Three Phase
CAPACITY	10.5kVa (8.4kW) to 80kVa (64KW)
VOLTAGE	1,500 rpm, 415 / 240 V, 50 Hz



TYPE	Hino and Komatsu Engines, Three Phase
CAPACITY	100kVa (80kW) to 800kVa (640kW)
VOLTAGE	1,500 rpm, 415 / 240 V, 50 Hz



AIRMAN OPTIONS	<ul style="list-style-type: none"> • Long Range Bunded Tanks • Ultra Silent Enclosures - 51 dB(A) at 1.7m
-----------------------	---



TYPE	Mitsubishi Diesel Three Phase
CAPACITY	16 kVA (12.8kW) to 22kVA (17.6kW)
VOLTAGE & SPEED	1,500 rpm, 415 / 240 V, 50 Hz



TYPE	John Deere Engine Three Phase
CAPACITY	33 kVA (26.4kW) to 250 kVA (200kW)
VOLTAGE & SPEED	1,500 rpm, 415 / 240 V, 50 Hz



TYPE	Volvo Penta Engine Three Phase
CAPACITY	275 kVA (220kW) to 700 kVA (560kW)
VOLTAGE & SPEED	1,500 rpm, 415 / 240 V, 50 Hz



TYPE	Mitsubishi Engine Three Phase
CAPACITY	1,400 kVA (1,120kW) to 2,500 kVA (2,000kW)
VOLTAGE & SPEED	1,500 rpm, 415 / 240 V, 50 Hz, other voltage up to 11 kV

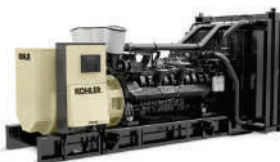

TYPE	Kohler Diesel Three Phase
CAPACITY	900 kVA (720KW) to 4,200 kVA (3,360KW)
VOLTAGE & SPEED	1,500 rpm, 415 / 240V, 50 Hz, other voltage up to 11 kV



TYPE	Automatic Transfer Switches
DESCRIPTION	Designed to interface with KOHLER generators and switchgear

GET IN TOUCH.

24/7 SUPPORT: 1800 800 878

WEBSITE: CAPS.COM.AU

SHOP: CAPSSHOP.COM.AU

EMAIL: INFO@CAPS.COM.AU

BRANCH LOCATIONS

PERTH (HEAD OFFICE) | KALGOORLIE | MELBOURNE | SYDNEY
NEWCASTLE | ADELAIDE | BRISBANE | MACKAY | DARWIN

**SOLVING YOUR
AIR AND POWER
CHALLENGES.**