

STOCK AIR RECEIVERS.

Air receivers help to eliminate pulsation in the discharge line, reduce load cycles, and act as storage. Selecting an appropriately sized receiver to match your compressed air needs are important.

QUALITY ACCREDITED

CAPS air receivers are designed to Australian design code AS1210 and manufacturing code AS3920.1.

OTHER PRESSURE VESSEL RANGE

- Gas scrubber vessels
- Surge vessels
- Vacuum vessels
- Knock out pots
- Air manifolds
- Large filter housings
- Air cannons
- Sand filters



INCLUSIONS

- Design code = AS1210 Class 3
- Packing = plastic wrapped and in open slated crate
- Support legs with pre drilled base plates
- Inspection opening
- Quality steel (shell & heads)
- Manufacturer's data report

OPTIONS

- Air receiver fittings kit including pressure gauge, drain valve and reducing bushes
- Mechanical auto drain
- Electronic auto drain

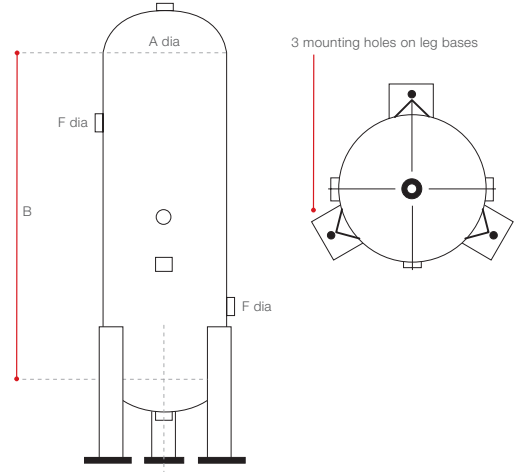

STOCK AIR RECEIVER SPECIFICATION

MODEL	DESIGN PRESSURE (KPA)	VOLUME (LITRE)	INLET/OUTLET CONNECTIONS (INCHES)	PSV CONNECTION (BSP)	APPROX SHIPPING WEIGHT (KG)	DIMENSIONS (MM)		
						DIA	SHELL	EST. OVERALL HEIGHT
VR500	1,550	500	2" BSP	3/4" BSP	280	608	1,530	2,200
VR850	1,250	850	2" BSP	1" BSP	330	780	1,510	2,300
VR1200	1,100	1,200	2" BSP	1" BSP	430	930	1,450	2,300
VR2000	1,100	2000	2" BSP	1" BSP	550	1,100	1,750	2,700

- Internal = grit blasted and shop primer
- External = grit blasted, shop primer and gloss finish
- All sizes and dimensions are for reference only and are subject to change without prior notice
- Unless otherwise stated, all standard vessels are quoted including aqua blue external finish, inspection openings and openings for drain, safety valve, gauge and at least one spare opening
- Air receiver fittings kits (gauge, drain valve, safety valve etc) are quoted separately and supplied to suit the design pressure of the vessel